

2A SERIES

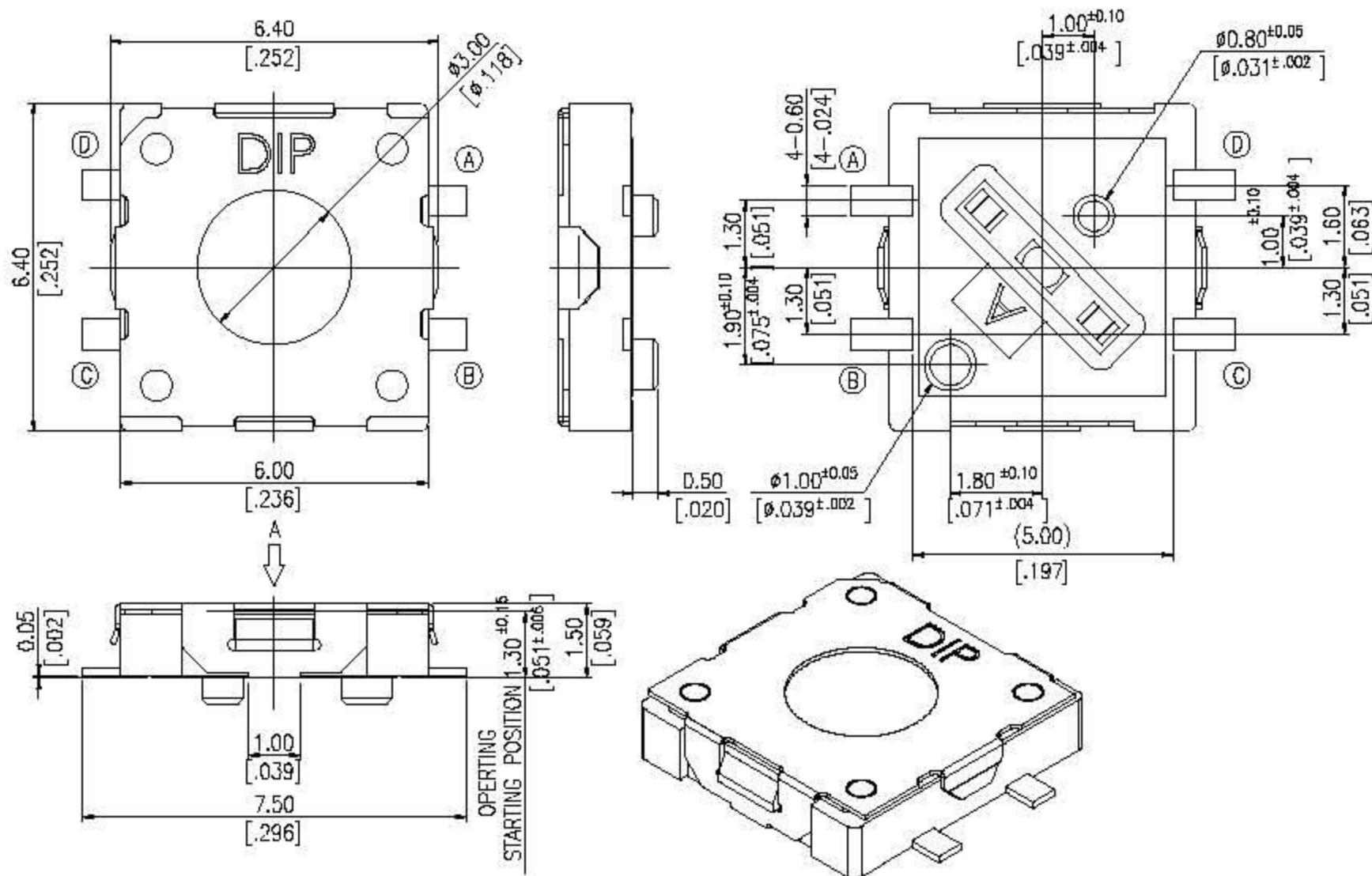

DIMENSIONS

2A-F



P.C.B LAYOUT (VIEW FROM THE DIRECTION A)

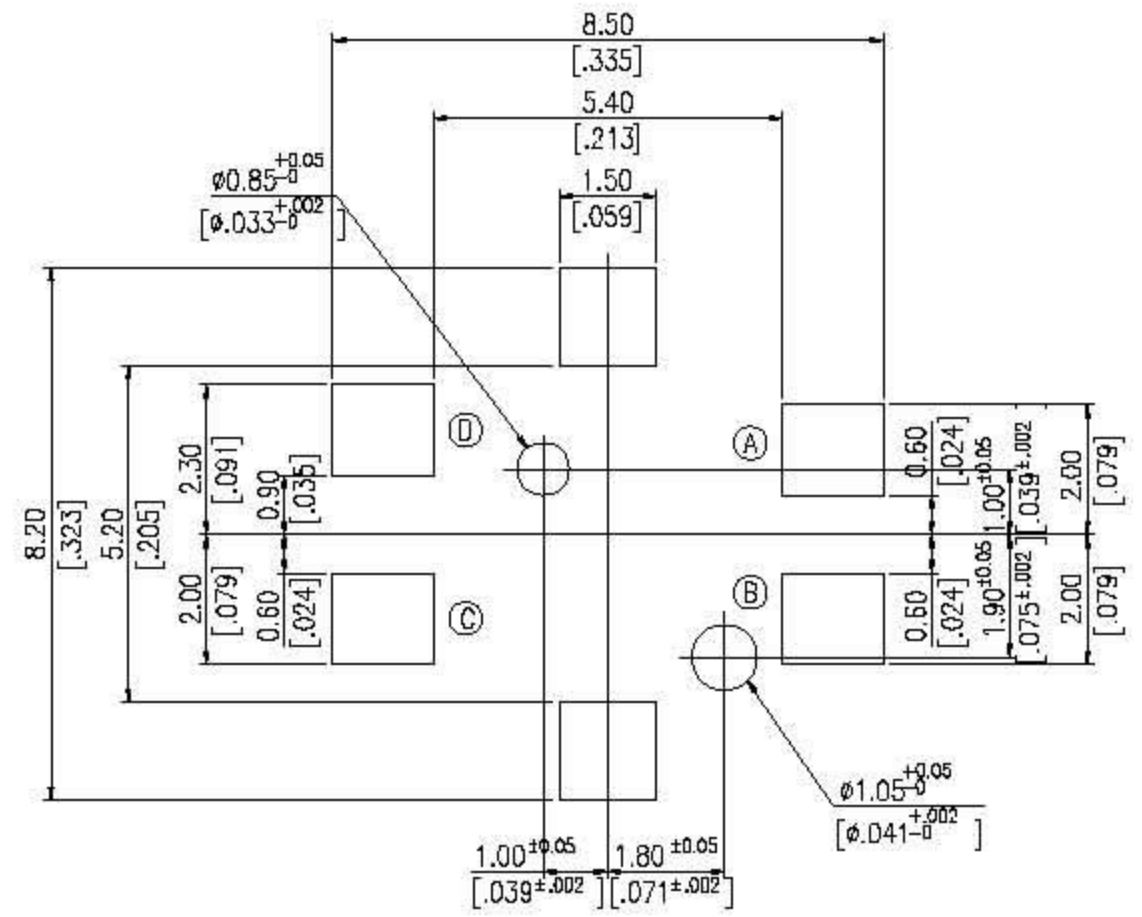

CIRCUIT

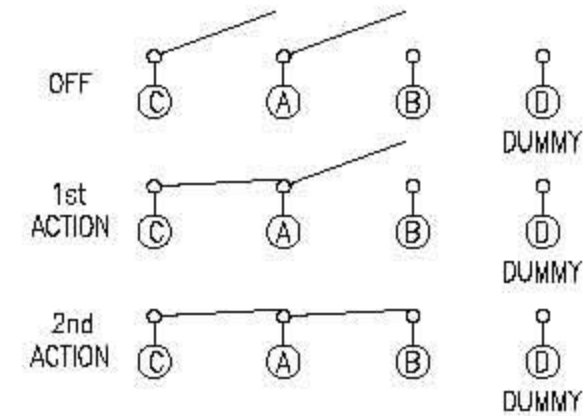

GENERAL TOLERANCES MAX:±0.2mm.

2A-L

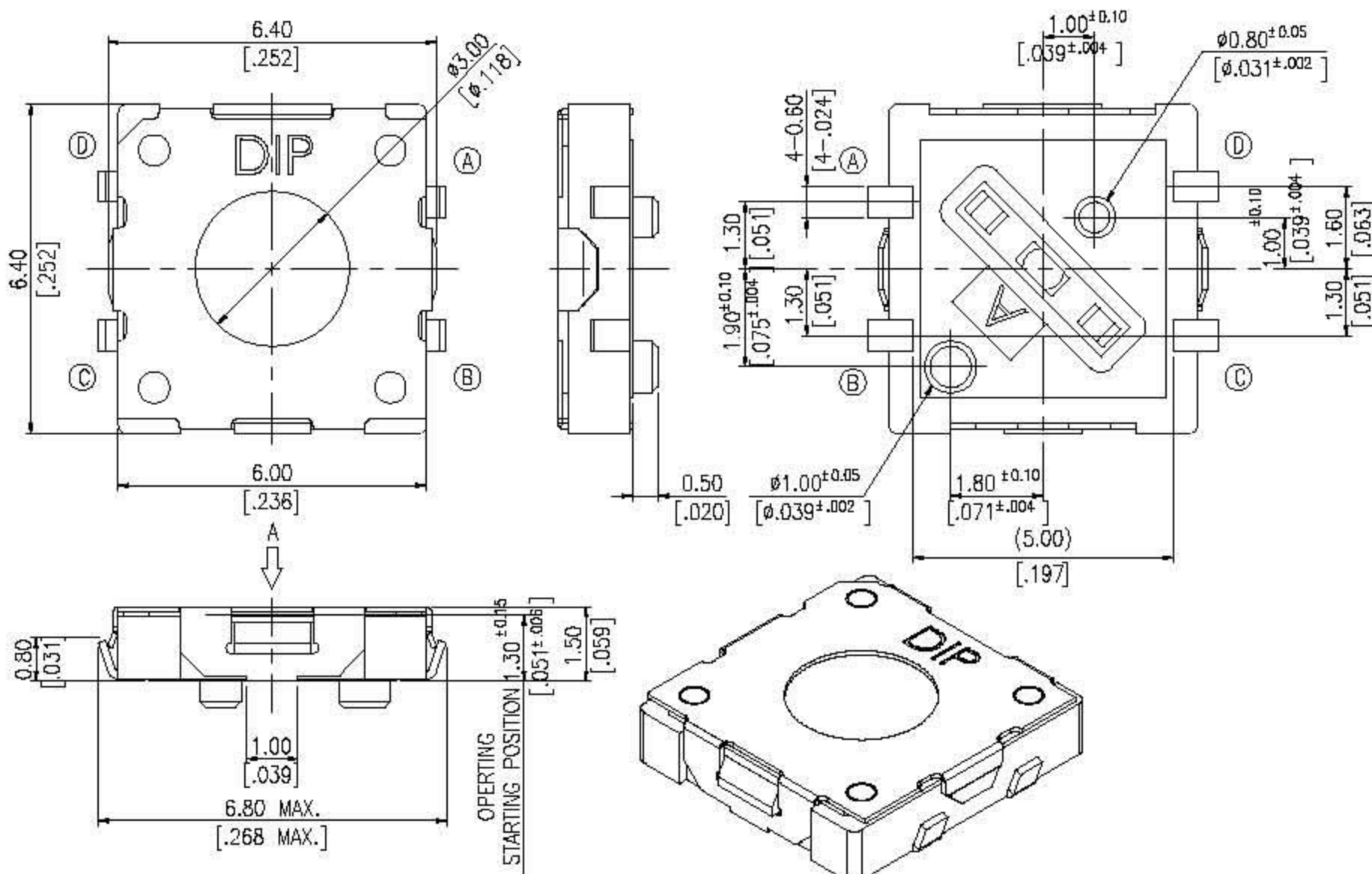

P.C.B LAYOUT (VIEW FROM THE DIRECTION A)

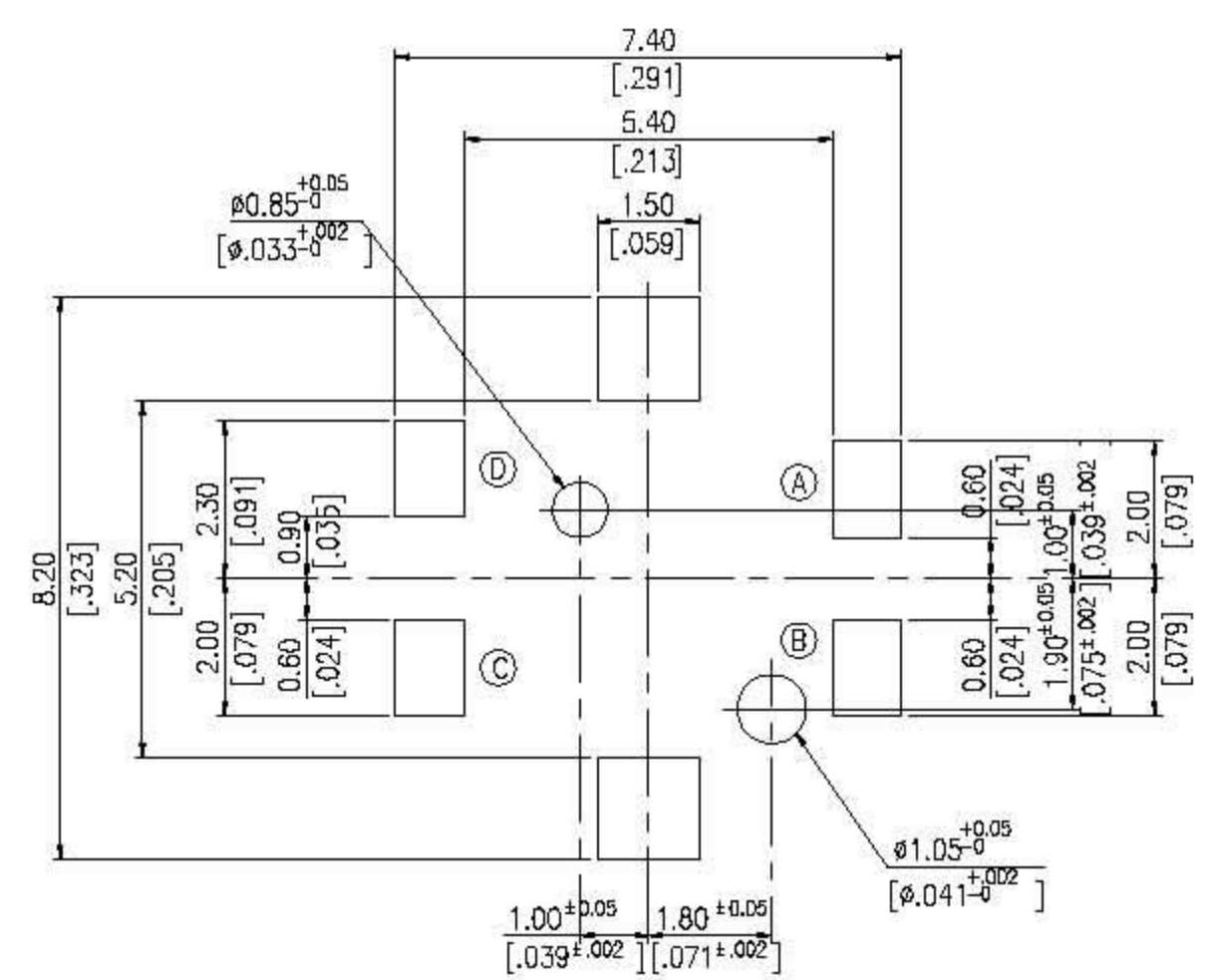

CIRCUIT

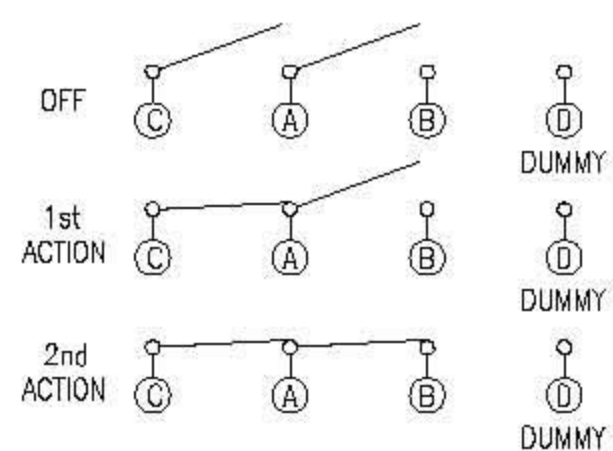

GENERAL TOLERANCES MAX:±0.2mm.

2A-□F

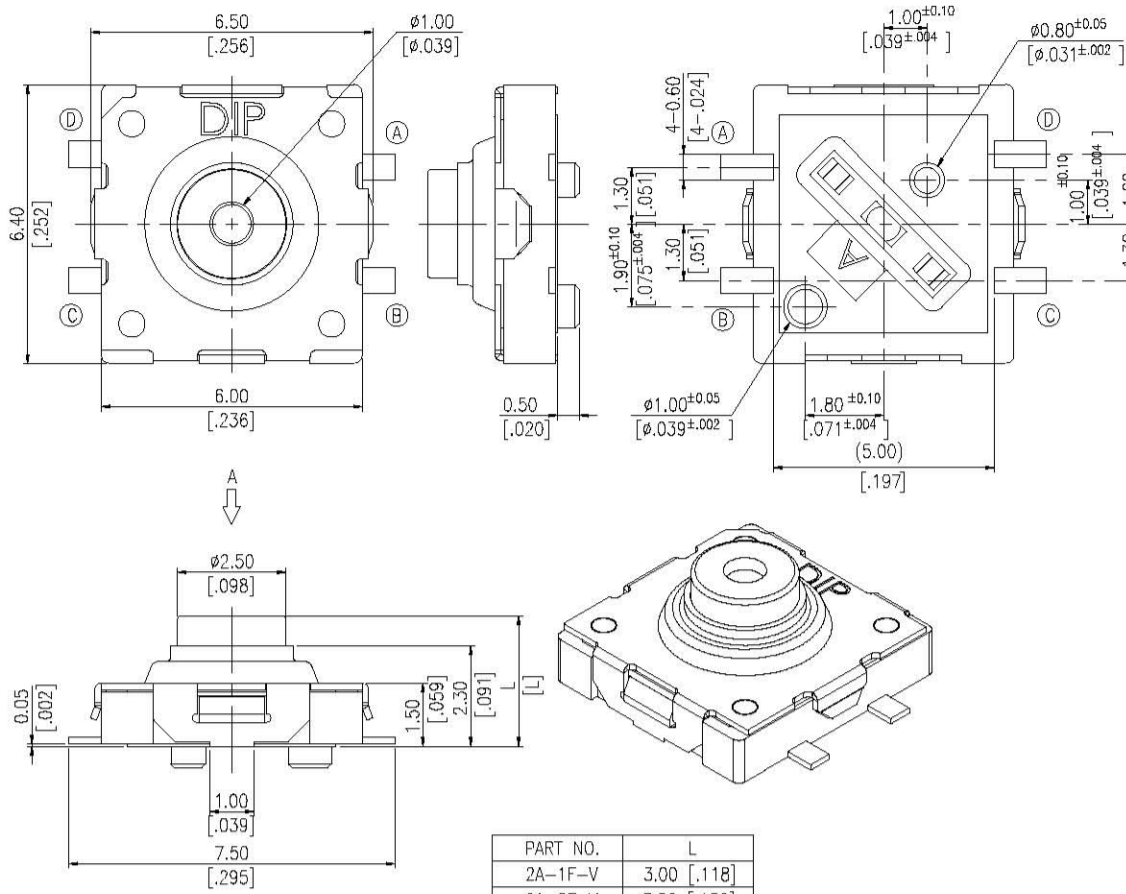

PART NO.	L
2A-1F-V	3.00 [0.118]
2A-2F-V	3.80 [0.150]

P.C.B LAYOUT
(VIEW FROM THE DIRECTION A)

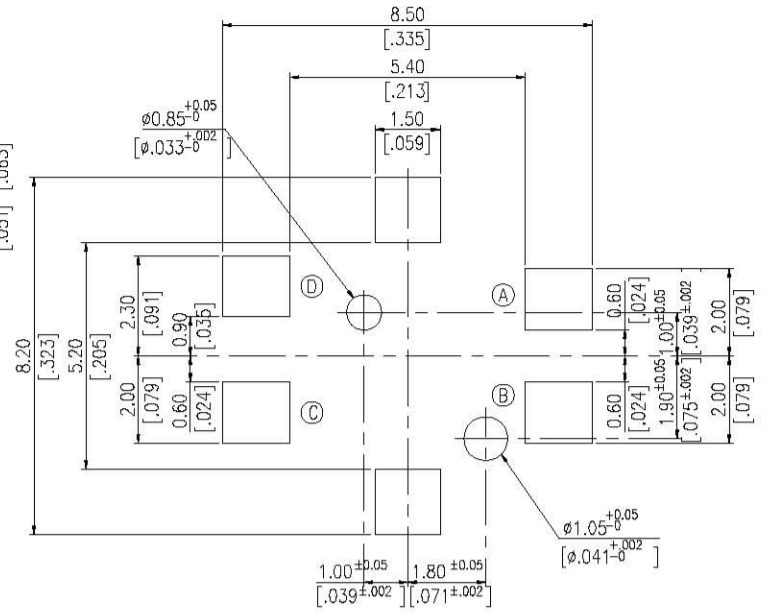

CIRCUIT

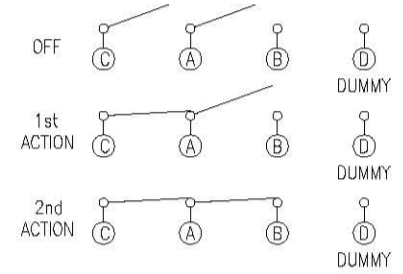

GENERAL TOLERANCES MAX:±0.2mm.

2A-□L

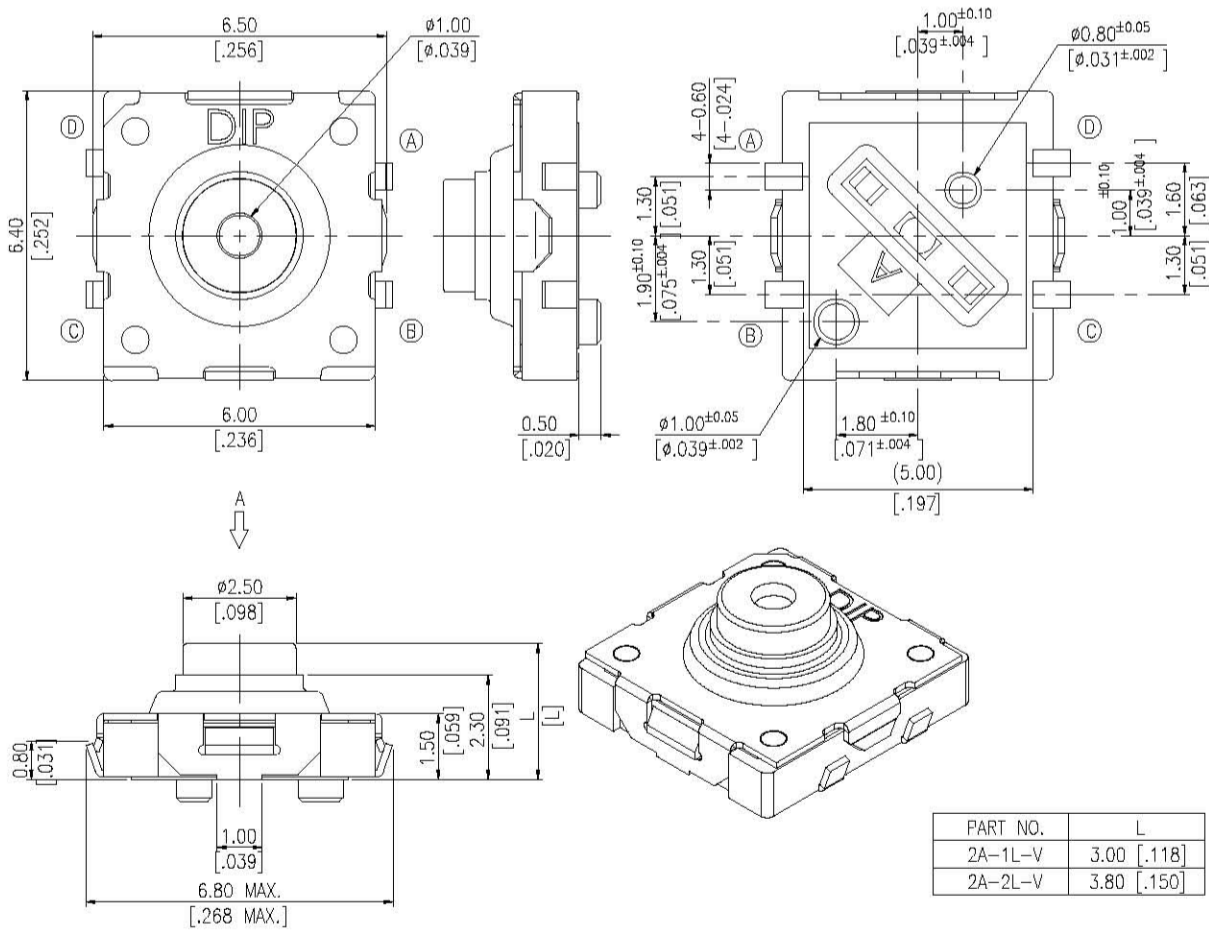

PART NO.	L
2A-1L-V	3.00 [0.118]
2A-2L-V	3.80 [0.150]

P.C.B LAYOUT
(VIEW FROM THE DIRECTION A)

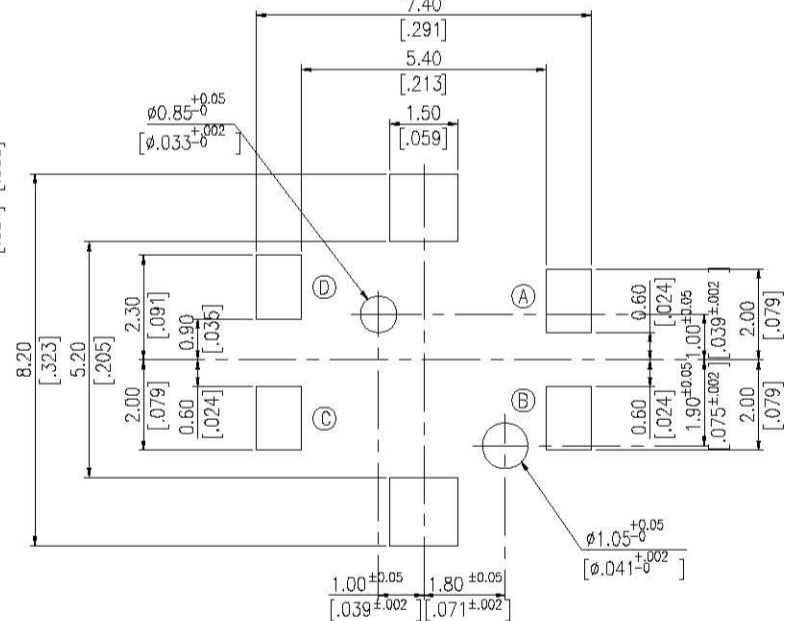

CIRCUIT

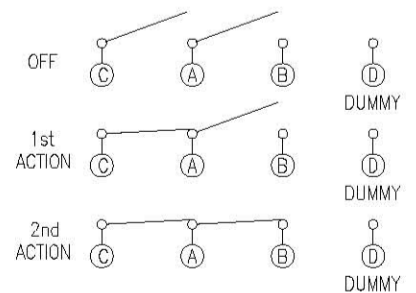

GENERAL TOLERANCES MAX:±0.2mm.

HOW TO ORDER

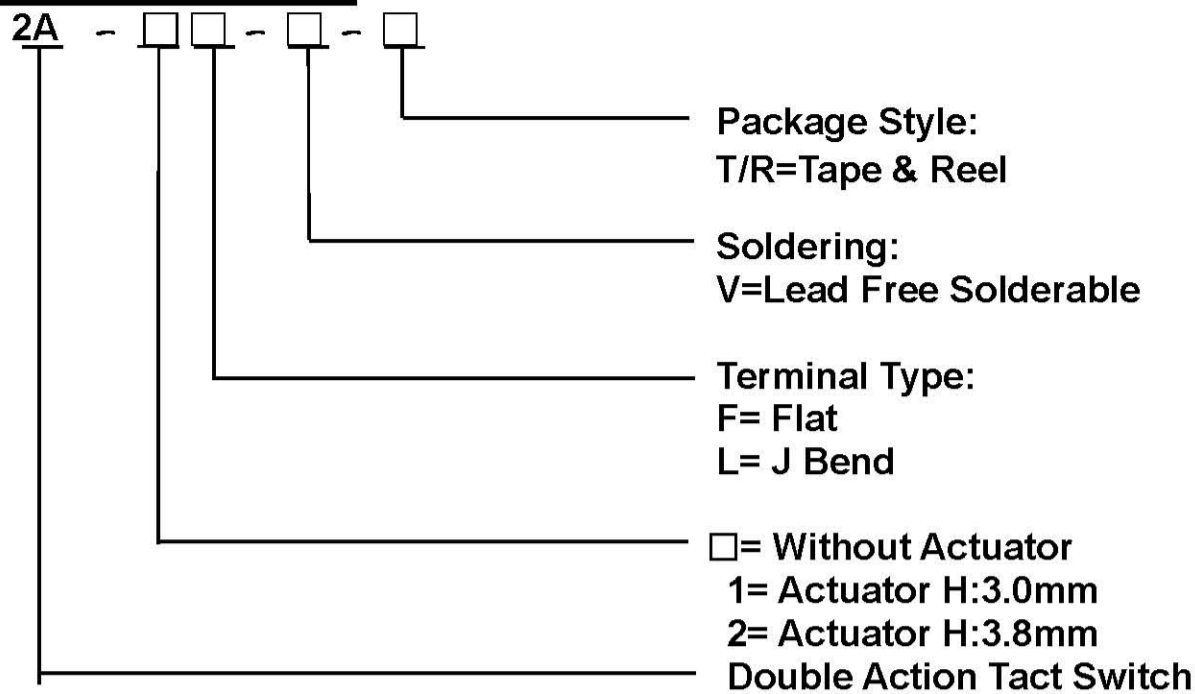

SPECIFICATION

△MECHANICAL

Operation Force: 1st 100 ±50gf
 2nd 260 +70gf / -50gf

Stroke: 1st 0.50 +0.10 / -0.20 mm
 2nd 0.70 +0.10 / -0.30 mm

Operation Temperature: -25°C to +70°C

Storage Temperature: -30°C to +80°C

△ELECTRICAL

Electrical Life: 30,000 cycles

Rating: 50mA , 12VDC

Contact Resistance: 100mΩ max.

Insulation Resistance: 100MΩ min. at 100VDC

Dielectric Strength: 250VAC/1 minute

Contact Arrangement: 1 pole 2 throw

MATERIAL

△COVER: Nickel silver

△BASE: UL 94V-0 Nylon high-temp Thermoplastic
 Color: Black

△DUSTCOVER: PTFE
 Color: White

△CONTACT DISC: Stainless with silver cladding

△TERMINAL: Copper alloy with silver plated

△SETM: UL 94V-0 Nylon high-temp Thermoplastic
 Color: Black

RECOMMENDED OPERATING CONDITIONS

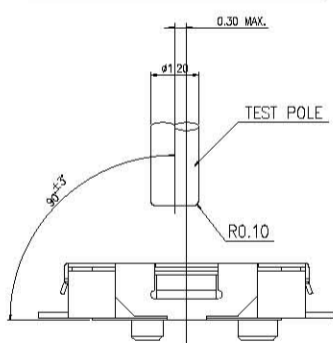

OPERATING FORCE - TRAVEL CHART

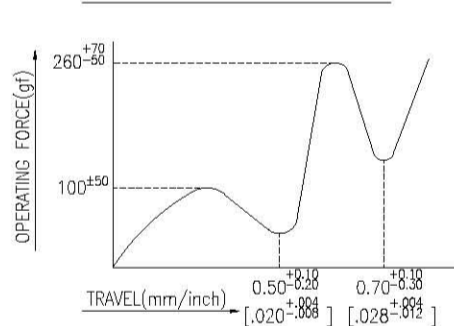

SOLDERING PROCESS

△HAND SOLDERING: Use a soldering iron of 30 watts, controlled at 350°C approximately max 5 seconds.

△Reflow Temperature Profile:

△REFLOW SOLDERING: When applying reflow soldering, the peak temperature or the reflow oven should be set at 260°C max.

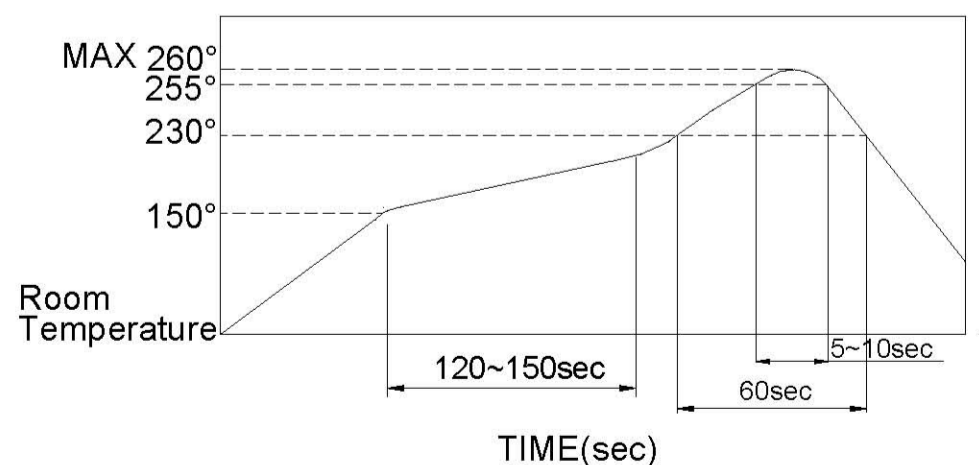

PACKING

Part Number	Number Per Tube	Number Per Reel
2A-F(L)	-	3000
2A-□F(L)	-	2000

2A-F(L) REEL

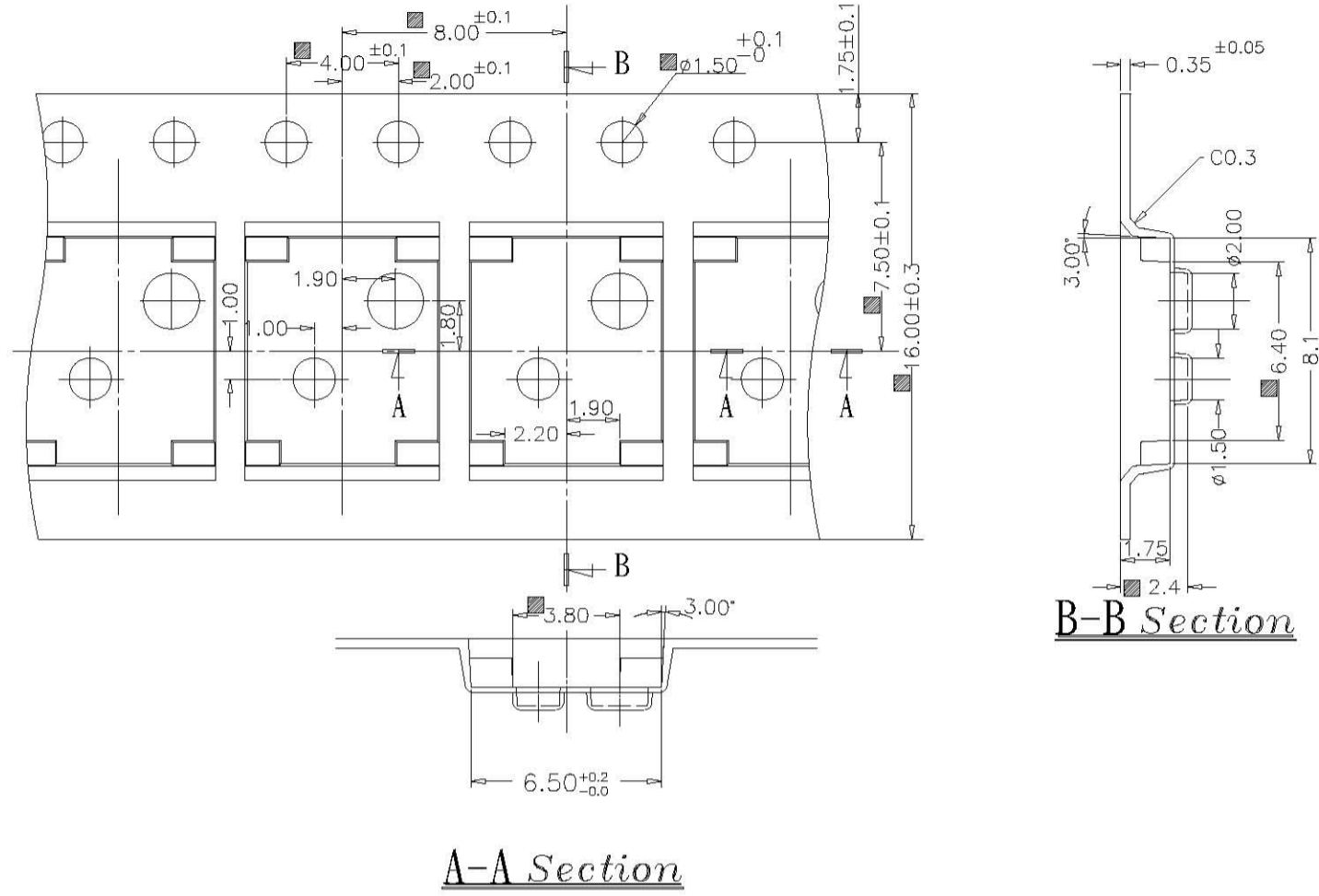

GENERAL TOLERANCES MAX:±0.1mm.

2A-1F(L) REEL

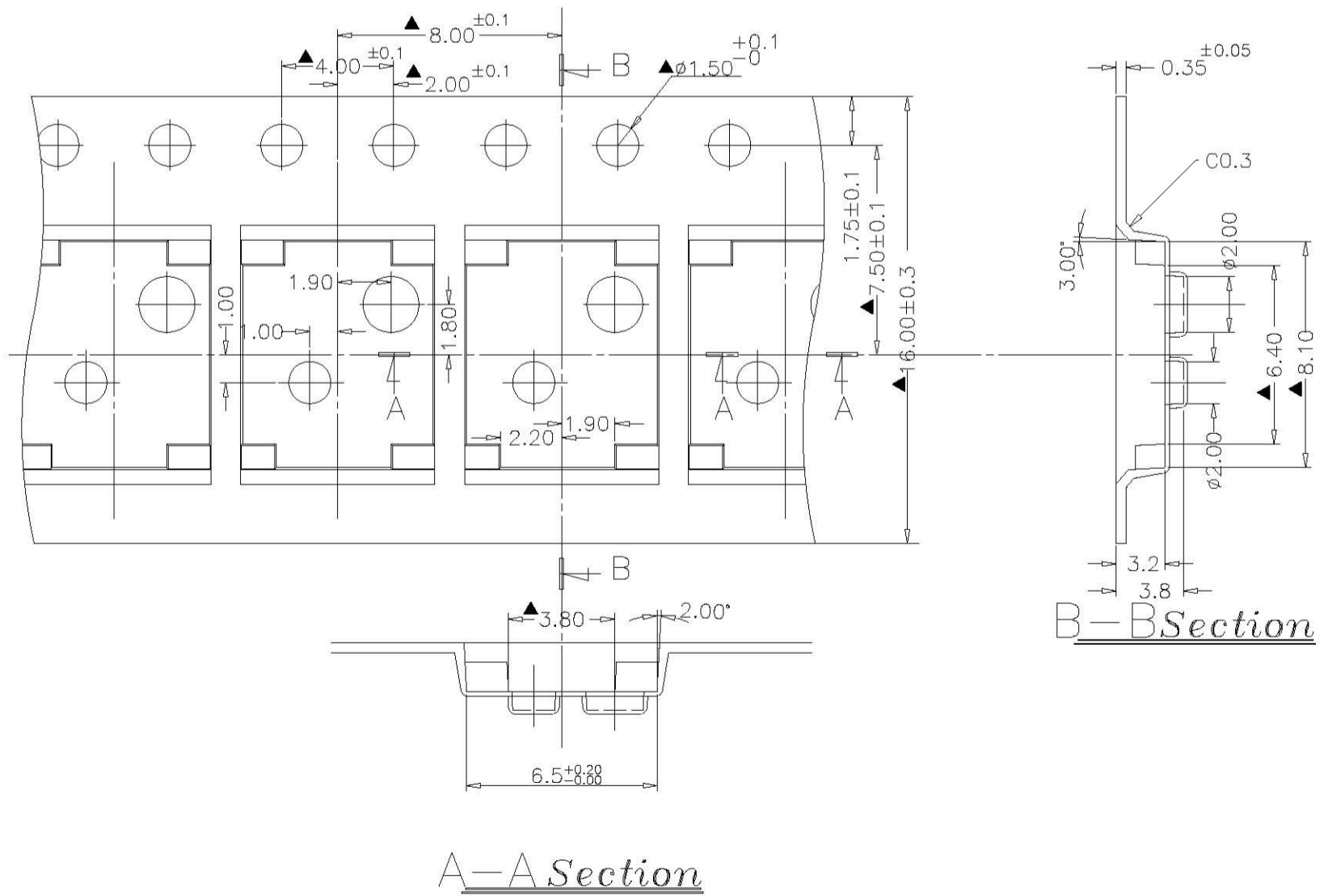

GENERAL TOLERANCES MAX:±0.1mm.

